

GENIE SX-125XC

TELESCOPIC BOOM LIFTS

Specifications

Models	SX-125 XC	
Measurements	US	Metric
Working height max. ⁽¹⁾	131 ft	40.10 m
Platform height max.	125 ft	38.10 m
Horizontal reach max.	80 ft	24.38 m
Below ground reach	8 ft 10 in	2.69 m
A Platform length (8 ft/6 ft)	3 ft/2 ft 6 in	0.91 m/0.76 m
B Platform width (8 ft/6 ft)	8 ft/6 ft	2.44 m/1.83 m
C Height - stowed	10 ft	3.05 m
D Length - stowed	46 ft 9 in	14.25 m
D Length - storage/transport (jib tucked under)	40 ft	12.19 m
E Width (axles retracted)	8 ft 2 in	2.49 m
E Width (axles extended)	12 ft 11 in	3.94 m
F Wheelbase	13 ft 6 in	4.11 m
G Ground clearance - center	15 in	0.38 m
H Height under counterweight	4 ft	1.22 m

Productivity

Lift capacity max. - unrestricted	660 lb	300 kg
Lift capacity max. - restricted	1,000 lb	454 kg
Number of Platform Occupants (restricted/unrestricted)		3/2
Platform rotation		160°
Jib length	5 ft	1.52 m
Vertical jib rotation (up/down)		135°
Turntable rotation		360°
Turntable tailswing (axles retracted)	1 ft 10 in	0.56 m
Turntable tailswing (axles extended)	3 ft 4 in	1.02 m
Drive speed - stowed	3.0 mph	4.9 km/h
Drive speed - raised	0.38 mph	0.6 km/h
Gradeability - stowed ⁽²⁾		40%
Tilt sensor activation (front to back/side to side)		4.5° / 3°
Turning radius - inside/outside (axle retracted)	26 ft 4 in/32 ft 8 in	8.03 m/9.96 m
Turning radius - inside/outside (axle extended)	9 ft 6 in/20 ft 3 in	2.90 m/6.17 m
Tires	445D50/710	

Power

Power	Diesel	
Hydraulic tank capacity	55 gal	208 L
Fuel tank capacity	40 gal	151 L

Weight⁽³⁾ and Floor Loading⁽⁴⁾

Weight	45,636 lb	20,700 kg
Tire contact pressure	102 psi	700 kPa
Occupied floor pressure, axles retracted/ extended	324 psf/ 205 psf	15.52 kPa/ 9.81 kPa

Sound and Vibration Levels

Sound Pressure level (ground workstation)	91 dBA
Sound Pressure level (platform workstation)	75 dBA
Vibrations	< 2.5 m/s ²

Range of motion SX-125 XC

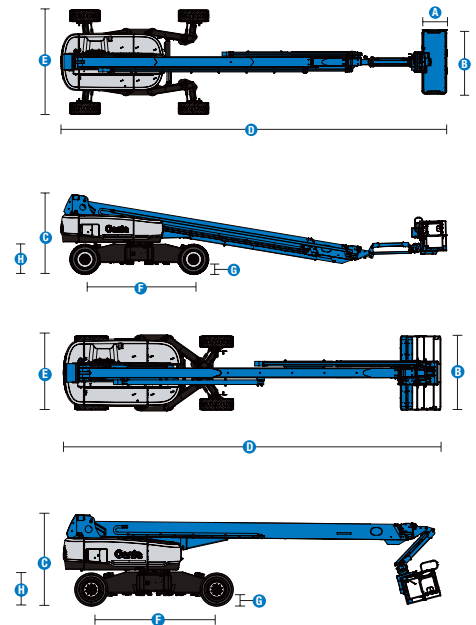
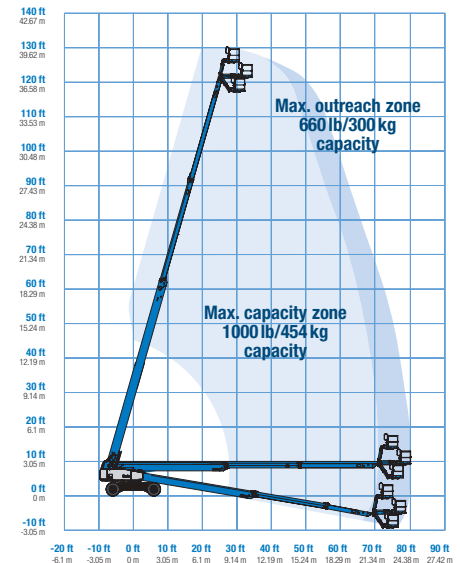

(1) The metric equivalent of working height adds 2m to platform height. The imperial equivalent adds 6ft to platform height.
 (2) Gradeability applies to driving on slopes and may vary depending on options and machine configurations. See operator's manual for details regarding slope ratings.
 (3) Weight refers to standard configuration and may vary depending on options and/or country standards.
 (4) Floor loading information is approximate and may vary depending on options and machine configurations. It should be used only with adequate safety factors.

GENIE SX-125XC

TELESCOPIC BOOM LIFTS



Experience | Safety | Innovation

SKU: Standard Model

- **SX125XC1UI0014:** SX-125 XC, Lift Power 7.5kW Generator Welder Ready, 4WD

* Build to Order

Option availability		S	S+	BtO
Power	74 hp, 55 kW, Deutz TD2011, Turbo Diesel, T4i/Stage IIIA/CN III	✓	✓	✓
	Battery Isolation Kit		○	○
	Battery and Starter Isolation Kit		○	○
	Anti-restart engine protection	✓	✓	✓
	Auto engine fault shutdown	✓	✓	✓
	In cylinder glow plug (diesel only)	✓	✓	✓
Platform	8ft/2.44m tri-entry platform with side swing gate	✓	✓	✓
	Thumb rocker steering	✓	✓	✓
	240Volt Power To Platform Kit			○
	Airline to Platform			○
	Half Mesh Aluminium 8FT TRI-ENTRY Platform Kit			○
	Harness Container Double		○	○
	Harness Container Single Kit		○	○
	Harness Fall Arrest Lanyard		○	○
	Platform Worklights		○	○
	White Noise Alarm Kit			○
	4 Steering modes	✓	✓	✓
	660lb/300kg & 1000lb/454kg dual load capacity with automatic envelope control	✓	✓	✓
	Drive enable system	✓	✓	✓
	Horn	✓	✓	✓
	Lift Guard Contact Alarm	✓	✓	○
	Lift Tools Work Tray	✓	✓	✓
	Platform control cover	✓	✓	✓
	Platform load sense system	✓	✓	✓
	Proportional controls	✓	✓	✓
	Self-leveling platform	✓	✓	✓
Chassis	Lift Connect Telematics		○	○
	Telematics-ready	✓	✓	✓
	Lift Connect with Access Manager upgrade		○	○
	Drive Lights		○	○
	Fire Extinguisher 4.5KG 4A:80B:E		○	○
	Wheel Chock Kit		○	○
	Wheel Nut Indicator		○	○
	2 speed wheel motors	✓	✓	✓
	Alarm package: includes flashing beacon and travel alarm	✓	✓	✓
	Descent, tilt and motion alarm	✓	✓	✓
	Dual battery system	✓	✓	✓
	Hour meter	✓	✓	✓
	Hydraulic oil cooler	✓	✓	✓
Mini XChassis extendable axles	✓	✓	✓	
Rough terrain, foam-filled tyres	✓	✓	✓	
Tech Pro Link connector	✓	✓	✓	

- S Standard
- S+ Standard +
- BtO Build to Order
- ✓ Standard Features
- Options



Xtra Capacity



Mini XChassis



Smooth Envelope

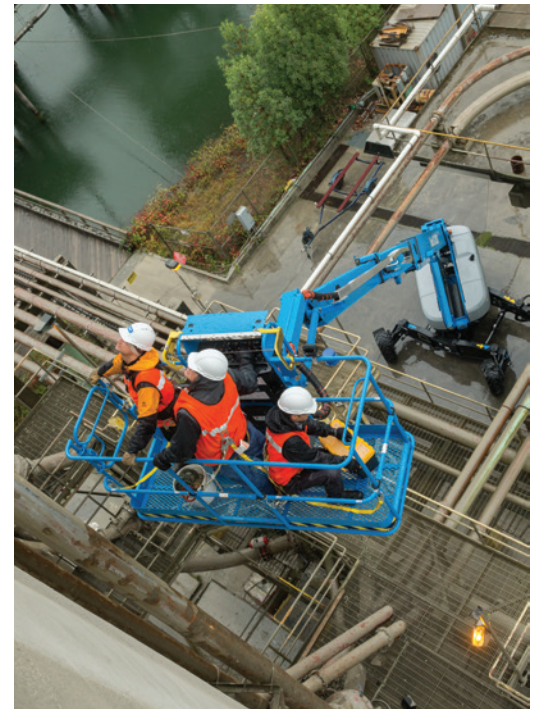

Genie Genuine Accessories⁽¹⁾

- Lift Tools Productivity Tools
- Lift Connect Telematics
- Tech Pro Link Handheld Device

(1) More accessories available from Genie Genuine Parts.

Product specifications are subject to change without notice or obligation. Photographs and/or drawings herein are for illustrative purposes only. Refer to the appropriate Operator's Manual for instructions on proper equipment use. Failure to follow instructions in the Operator's Manual may result in serious injury or death. The only warranty applicable to our equipment is the standard written warranty applicable to the particular product and sale and we make no other warranty, express or implied. Products and services listed may be trademarks, service marks or trade names of Terex Corporation and/or their subsidiaries in the USA and many other countries. Terex, Genie, Quality By Design, Xtra Capacity, Lift Power, Lift Guard, Lift Tools, Lift Connect and Tech Pro Link are registered trademarks of Terex Corporation or its subsidiaries.

05/23